

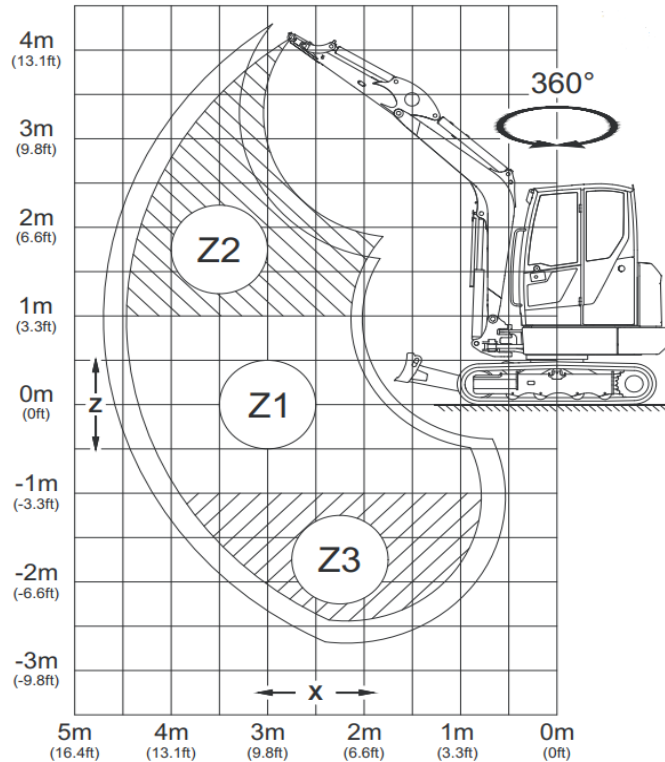

Lifting force tables ET58



All table values are specified in kg (lbs.), in a horizontal position on a solid surface and without a bucket or an attachment,

If a bucket or other attachment is mounted, the lifting force or tipping load is reduced by the device's dead weight,
Base of calculation: according to ISO 10567,

The lifting force of the vehicle is limited by the settings of the pressure relief valves and hydraulic performance or by the tipping safety mechanism,

Neither 75% of the static tipping load nor 87% of the hydraulic lifting force are exceeded, The lifting force of the vehicle is limited by the hydraulic capacity or by the tilting safety mechanism,

Neither 75% of the static tipping load nor 87% of the hydraulic lifting force are exceeded,

Base of calculation: according to ISO 10567, Set pressure at the lifting arm cylinder: ET 24: 24000 kPa (3480 psi)

The lifting capability applies for vehicles under the following conditions:

- Lubricants and operating materials at the prescribed levels,
- Full fuel tank,
- Cabin
- Vehicle at operating temperature,
- Weight of the operator 75 kg (165 lbs.),

| | |
|-----|---|
| max | Permissible load with extended dipper stick |
| A | Outreach from middle of rotating assembly |
| B | Load hook height |
| * | Lifting force limited by hydraulics |
| | With or without dozer blade support in travel direction |
| | With or without dozer blade support 90° from the travel direction |



**WACKER
NEUSON**
all it takes!

Lifting force tables ET58

| | | | | | 5,0 m (16'-5") | | | 4,0 m (13'-1") | | | 3,0 m (9'-10") | | | 2,0 m (6'-7") | | |
|--------------------|--------------------|------------------|------------------|--------------------|----------------|----------------|--------------------|------------------|------------------|--------------------|------------------|------------------|--------------------|--------------------|------------------|-------------------|
| A B | Blade down | Blade up | | Blade down | Blade up | | Blade down | Blade up | | Blade down | Blade up | | Blade down | Blade up | | |
| | | | | | | | | | | | | | | | | 4,0 m (13'-1") |
| 3,0 m (9'-10") | 1,304* (2,876)* | 912 (2,011) | 841 (1,854) | - | - | - | 1,295* (2,856)* | 1,161 (2,559) | 1,066 (2,351) | - | - | - | - | - | - | |
| 2,0 m (6'-7") | 1,311* (2,892)* | 805 (1,776) | 743 (1,638) | - | - | - | 1,463* (3,226)* | 1,128 (2,488) | 1,035 (2,282) | 1,850* (4,080)* | 1,760 (3,880) | 1,590 (3,506) | - | - | - | |
| 1,0 m (3'-3") | 1,335* (2,944)* | 771 (1,701) | 711 (1,568) | 1,355* (2,988)* | 789 (1,740) | 728 (1,604) | 1,678* (3,700)* | 1,088 (2,399) | 996 (2,196) | 2,413* (5,322)* | 1,659 (3,659) | 1,495 (3,296) | - | - | - | |
| 0,0 m (0'-0") | 1,365* (3,010)* | 794 (1,751) | 731 (1,613) | - | - | - | 1,800* (3,968)* | 1,059 (2,336) | 969 (2,136) | 2,645* (5,832)* | 1,607 (3,543) | 1,445 (3,186) | - | - | - | |
| -1,0 m (-3'-3") | 1,386* (3,057)* | 893 (1,970) | 821 (1,810) | - | - | - | 1,716* (3,785)* | 1,053 (2,322) | 962 (2,122) | 2,504* (5,522)* | 1,599 (3,527) | 1,438 (3,171) | 4,032* (8,891)* | 3,256 (7,179) | 2,790 (6,152) | |
| -2,0 m (-6'-7") | 1,348* (2,973)* | 1,180 (2,602) | 1,077 (2,374) | - | - | - | - | - | - | 1,957* (4,314)* | 1,627 (3,587) | 1,464 (3,228) | 3,009* (6,635)* | 3,009* (6,635)* | 2,842 (6,267) | |

Tab.1: Lifting force table ET58 STD, short dipper stick, rubber track, without additional rear weight

| | | | | | 5,0 m (16'-5") | | | 4,0 m (13'-1") | | | 3,0 m (9'-10") | | | 2,0 m (6'-7") | | |
|--------------------|--------------------|------------------|----------------|--------------------|----------------|----------------|--------------------|------------------|------------------|--------------------|--------------------|------------------|--------------------|------------------|------------------|-------------------|
| A B | Blade down | Blade up | | Blade down | Blade up | | Blade down | Blade up | | Blade down | Blade up | | Blade down | Blade up | | |
| | | | | | | | | | | | | | | | | 4,0 m (13'-1") |
| 3,0 m (9'-10") | 1,204* (2,654)* | 831 (1,833) | 767 (1,690) | - | - | - | 1,177* (2,595)* | 1,162 (2,562) | 1,067 (2,352) | - | - | - | - | - | - | |
| 2,0 m (6'-7") | 1,216* (2,680)* | 741 (1,634) | 684 (1,507) | 1,228* (2,709)* | 797 (1,757) | 734 (1,620) | 1,361* (3,001)* | 1,126 (2,483) | 1,032 (2,276) | 1,661* (3,662)* | 1,661* (3,662)* | 1,601 (3,530) | - | - | - | |
| 1,0 m (3'-3") | 1,241* (2,737)* | 711 (1,568) | 655 (1,445) | 1,306* (2,880)* | 779 (1,718) | 717 (1,581) | 1,600* (3,528)* | 1,081 (2,384) | 989 (2,180) | 2,270* (5,006)* | 1,662 (3,664) | 1,496 (3,299) | - | - | - | |
| 0,0 m (0'-0") | 1,273* (2,807)* | 729 (1,607) | 671 (1,479) | 1,341* (2,958)* | 765 (1,687) | 703 (1,551) | 1,762* (3,885)* | 1,047 (2,308) | 955 (2,107) | 2,598* (5,729)* | 1,594 (3,515) | 1,432 (3,157) | - | - | - | |
| -1,0 m (-3'-3") | 1,302* (2,870)* | 808 (1,783) | 743 (1,637) | - | - | - | 1,743* (3,843)* | 1,034 (2,279) | 943 (2,079) | 2,551* (5,625)* | 1,576 (3,476) | 1,415 (3,120) | 4,306* (9,494)* | 3,208 (7,073) | 2,745 (6,052) | |
| -2,0 m (-6'-7") | 1,296* (2,857)* | 1,024 (2,257) | 936 (2,063) | - | - | - | 1,368* (3,015)* | 1,051 (2,318) | 960 (2,117) | 2,126* (4,689)* | 1,595 (3,517) | 1,433 (3,160) | 3,393* (7,481)* | 3,260 (7,187) | 2,791 (6,155) | |

Tab.2: Lifting force table ET58 STD, long dipper stick, rubber track, without additional rear weight



Lifting force tables ET58

| | | | | | 5,0 m (16'-5") | | | 4,0 m (13'-1") | | | 3,0 m (9'-10") | | | 2,0 m (6'-7") | | |
|--------------------|---|--------------------|------------------|------------------|--------------------|----------------|----------------|--------------------|------------------|------------------|--------------------|--------------------|------------------|--------------------|--------------------|--------------------|
| A | B | | | | | | | | | | | | | | | |
| | | Blade down | Blade up | | Blade down | Blade up | | Blade down | Blade up | | Blade down | Blade up | | Blade down | Blade up | |
| 4,0 m (13'-1") | | - | - | - | - | - | - | - | - | - | - | - | - | - | - | - |
| 3,0 m (9'-10") | | 1,304* (2,876)* | 1,005 (2,216) | 927 (2,043) | - | - | - | 1,295* (2,856)* | 1,273 (2,807) | 1,169 (2,579) | - | - | - | - | - | - |
| 2,0 m (6'-7") | | 1,311* (2,892)* | 890 (1,963) | 822 (1,812) | - | - | - | 1,463* (3,226)* | 1,241 (2,736) | 1,138 (2,510) | 1,850* (4,080)* | 1,850* (4,080)* | 1,742 (3,840) | - | - | - |
| 1,0 m (3'-3") | | 1,335* (2,944)* | 854 (1,884) | 788 (1,738) | 1,355* (2,988)* | 874 (1,927) | 806 (1,777) | 1,678* (3,700)* | 1,200 (2,647) | 1,099 (2,424) | 2,413* (5,322)* | 1,828 (4,030) | 1,646 (3,630) | - | - | - |
| 0,0 m (0'-0") | | 1,365* (3,010)* | 880 (1,940) | 811 (1,788) | - | - | - | 1,800* (3,968)* | 1,172 (2,584) | 1,072 (2,363) | 2,645* (5,832)* | 1,775 (3,914) | 1,597 (3,521) | - | - | - |
| -1,0 m (-3'-3") | | 1,386* (3,057)* | 989 (2,181) | 909 (2,004) | - | - | - | 1,716* (3,785)* | 1,165 (2,570) | 1,066 (2,349) | 2,504* (5,522)* | 1,768 (3,898) | 1,590 (3,505) | 4,032* (8,891)* | 3,589 (7,913) | 3,076 (6,782) |
| -2,0 m (-6'-7") | | 1,348* (2,973)* | 1,303 (2,873) | 1,189 (2,621) | - | - | - | - | - | - | 1,957* (4,314)* | 1,795 (3,958) | 1,616 (3,563) | 3,009* (6,635)* | 3,009* (6,635)* | 3,009* (6,635)* |

Tab.3: Lifting force table ET58 STD, short dipper stick, rubber track, with additional rear weight

| | | | | | 5,0 m (16'-5") | | | 4,0 m (13'-1") | | | 3,0 m (9'-10") | | | 2,0 m (6'-7") | | |
|--------------------|---|--------------------|--------------------|------------------|--------------------|----------------|----------------|--------------------|--------------------|-------------------|--------------------|--------------------|--------------------|--------------------|--------------------|------------------|
| A | B | | | | | | | | | | | | | | | |
| | | Blade down | Blade up | | Blade down | Blade up | | Blade down | Blade up | | Blade down | Blade up | | Blade down | Blade up | |
| 4,0 m (13'-1") | | 1,220* (2,690)* | 1,146* (2,526)* | 1,054 (2,324) | - | - | - | 1,168* (2,576)* | 1,168* (2,576)* | 1,168* (2,576) | - | - | - | - | - | - |
| 3,0 m (9'-10") | | 1,204* (2,654)* | 918 (2,024) | 847 (1,867) | - | - | - | 1,177* (2,595)* | 1,177* (2,595)* | 1,170 (2,580) | - | - | - | - | - | - |
| 2,0 m (6'-7") | | 1,216* (2,680)* | 821 (1,811) | 758 (1,671) | 1,228* (2,709)* | 881 (1,944) | 813 (1,792) | 1,361* (3,001)* | 1,239 (2,731) | 1,136 (2,504) | 1,661* (3,662)* | 1,661* (3,662)* | 1,661* (3,662)* | - | - | - |
| 1,0 m (3'-3") | | 1,241* (2,737)* | 789 (1,741) | 728 (1,605) | 1,306* (2,880)* | 864 (1,904) | 795 (1,754) | 1,600* (3,528)* | 1,194 (2,632) | 1,092 (2,408) | 2,270* (5,006)* | 1,830 (4,035) | 1,648 (3,633) | - | - | - |
| 0,0 m (0'-0") | | 1,273* (2,807)* | 810 (1,785) | 746 (1,644) | 1,341* (2,958)* | 850 (1,873) | 782 (1,724) | 1,762* (3,885)* | 1,159 (2,556) | 1,059 (2,334) | 2,598* (5,729)* | 1,762 (3,886) | 1,584 (3,492) | - | - | - |
| -1,0 m (-3'-3") | | 1,302* (2,870)* | 898 (1,979) | 825 (1,819) | - | - | - | 1,743* (3,843)* | 1,146 (2,527) | 1,046 (2,307) | 2,551* (5,625)* | 1,745 (3,847) | 1,567 (3,455) | 4,306* (9,494)* | 3,541 (7,807) | 3,030 (6,682) |
| -2,0 m (-6'-7") | | 1,296* (2,857)* | 1,133 (2,499) | 1,036 (2,285) | - | - | - | 1,368* (3,015)* | 1,164 (2,567) | 1,063 (2,345) | 2,126* (4,689)* | 1,763 (3,888) | 1,585 (3,494) | 3,393* (7,481)* | 3,393* (7,481)* | 3,077 (6,785) |

Tab.4: Lifting force table ET58 STD, long dipper stick, rubber track, with additional rear weight



Lifting force tables ET58

| | | | | | 5,0 m (16'-5") | | | 4,0 m (13'-1") | | | 3,0 m (9'-10") | | | 2,0 m (6'-7") | | | | | |
|-----------------|---|--------------------|------------------|------------------|--------------------|----------------|----------------|--------------------|--------------------|------------------|--------------------|------------------|------------------|--------------------|--------------------|------------------|------------|----------|---|
| A | B | | | | | | | | | | | | | | | | | | |
| | | Blade down | Blade up | | Blade down | Blade up | | Blade down | Blade up | | Blade down | Blade up | | Blade down | Blade up | | Blade down | Blade up | |
| 4,0 m (13'-1") | | - | - | - | - | - | - | - | - | - | - | - | - | - | - | - | - | - | - |
| 3,0 m (9'-10") | | 1,304* (2,876)* | 942 (2,077) | 810 (1,756) | - | - | - | 1,295* (2,856)* | 1,198* (2,641)* | 1,027 (2,264) | - | - | - | - | - | - | - | - | - |
| 2,0 m (6'-7") | | 1,311* (2,892)* | 832 (1,835) | 716 (1,578) | - | - | - | 1,463* (3,226)* | 1,165 (2,569) | 996 (2,195) | 1,850* (4,080)* | 1,819 (4,010) | 1,524 (3,360) | - | - | - | - | - | - |
| 1,0 m (3'-3") | | 1,335* (2,944)* | 797 (1,758) | 685 (1,510) | 1,355* (2,988)* | 816 (1,799) | 700 (1,544) | 1,678* (3,700)* | 1,125 (2,480) | 957 (2,111) | 2,413* (5,322)* | 1,718 (3,788) | 1,430 (3,154) | - | - | - | - | - | - |
| 0,0 m (0'-0") | | 1,365* (3,010)* | 821 (1,811) | 704 (1,551) | - | - | - | 1,800* (3,968)* | 1,096 (2,417) | 930 (2,051) | 2,645* (5,832)* | 1,665 (3,671) | 1,381 (3,045) | - | - | - | - | - | - |
| -1,0 m (-3'-3") | | 1,386* (3,057)* | 924 (2,038) | 789 (1,740) | - | - | - | 1,716* (3,785)* | 1,090 (2,402) | 924 (2,037) | 2,504* (5,522)* | 1,658 (3,655) | 1,374 (3,030) | 4,032* (8,891)* | 3,391 (7,477) | 2,632 (5,804) | - | - | - |
| -2,0 m (-6'-7") | | 1,348* (2,973)* | 1,221 (2,691) | 1,033 (2,279) | - | - | - | - | - | - | 1,957* (4,314)* | 1,685 (3,716) | 1,400 (3,07) | 3,009* (6,635)* | 3,009* (6,635)* | 2,683 (5,916) | - | - | - |

Tab.5: Lifting force table ET58 STD, short dipper stick, steel track, without additional rear weight

| | | | | | 5,0 m (16'-5") | | | 4,0 m (13'-1") | | | 3,0 m (9'-10") | | | 2,0 m (6'-7") | | | | | |
|-----------------|---|--------------------|------------------|----------------|--------------------|----------------|----------------|--------------------|--------------------|------------------|--------------------|--------------------|------------------|--------------------|--------------------|------------------|------------|----------|---|
| A | B | | | | | | | | | | | | | | | | | | |
| | | Blade down | Blade up | | Blade down | Blade up | | Blade down | Blade up | | Blade down | Blade up | | Blade down | Blade up | | Blade down | Blade up | |
| 4,0 m (13'-1") | | 1,220* (2,690)* | 1,076 (2,373) | 923 (2,036) | - | - | - | 1,168* (2,576)* | 1,168* (2,576)* | 1,034 (2,280) | - | - | - | - | - | - | - | - | - |
| 3,0 m (9'-10") | | 1,204* (2,654)* | 859 (1,894) | 738 (1,628) | - | - | - | 1,177* (2,595)* | 1,177* (2,595)* | 1,027 (2,264) | - | - | - | - | - | - | - | - | - |
| 2,0 m (6'-7") | | 1,216* (2,680)* | 766 (1,690) | 658 (1,450) | 1,228* (2,709)* | 824 (1,816) | 707 (1,559) | 1,361* (3,001)* | 1,163 (2,565) | 993 (2,189) | 1,661* (3,662)* | 1,661* (3,662)* | 1,534 (3,383) | - | - | - | - | - | - |
| 1,0 m (3'-3") | | 1,241* (2,737)* | 736 (1,622) | 630 (1,390) | 1,306* (2,880)* | 806 (1,777) | 690 (1,521) | 1,600* (3,528)* | 1,118 (2,465) | 950 (2,095) | 2,270* (5,006)* | 1,721 (3,794) | 1,431 (3,156) | - | - | - | - | - | - |
| 0,0 m (0'-0") | | 1,273* (2,807)* | 754 (1,663) | 645 (1,422) | 1,341* (2,958)* | 792 (1,746) | 676 (1,491) | 1,762* (3,885)* | 1,083 (2,389) | 917 (2,022) | 2,598* (5,729)* | 1,652 (3,643) | 1,368 (3,016) | - | - | - | - | - | - |
| -1,0 m (-3'-3") | | 1,302* (2,870)* | 837 (1,845) | 714 (1,573) | - | - | - | 1,743* (3,843)* | 1,070 (2,360) | 904 (1,994) | 2,551* (5,625)* | 1,635 (3,604) | 1,351 (2,980) | 4,306* (9,494)* | 3,342 (7,370) | 2,588 (5,706) | - | - | - |
| -2,0 m (-6'-7") | | 1,296* (2,857)* | 1,059 (2,336) | 898 (1,981) | - | - | - | 1,368* (3,015)* | 1,088 (2,399) | 921 (2,032) | 2,126* (4,689)* | 1,653 (3,646) | 1,369 (3,019) | 3,393* (7,481)* | 3,393* (7,481)* | 2,633 (5,806) | - | - | - |

Tab.6: Lifting force table ET58 STD, long dipper stick, steel track, without additional rear weight



Lifting force tables ET58

| | | | | | 5,0 m (16'-5") | | | 4,0 m (13'-1") | | | 3,0 m (9'-10") | | | 2,0 m (6'-7") | | |
|--------------------|---|--------------------|------------------|------------------|--------------------|----------------|----------------|--------------------|--------------------|------------------|--------------------|--------------------|------------------|--------------------|--------------------|------------------|
| A | B | | | | | | | | | | | | | | | |
| | | Blade down | Blade up | | Blade down | Blade up | | Blade down | Blade up | | Blade down | Blade up | | Blade down | Blade up | |
| 4,0 m (13'-1") | | - | - | - | - | - | - | - | - | - | - | - | - | - | - | - |
| 3,0 m (9'-10") | | 1,304* (2,876)* | 1,036 (2,283) | 894 (1,971) | - | - | - | 1,295* (2,856)* | 1,295* (2,856)* | 1,127 (2,485) | - | - | - | - | - | - |
| 2,0 m (6'-7") | | 1,311* (2,892)* | 918 (2,024) | 792 (1,747) | - | - | - | 1,463* (3,226)* | 1,279* (2,820)* | 1,096 (2,417) | 1,850* (4,080)* | 1,850* (4,080)* | 1,671 (3,684) | - | - | - |
| 1,0 m (3'-3") | | 1,335* (2,944)* | 881 (1,943) | 760 (1,675) | 1,355* (2,988)* | 901 (1,987) | 777 (1,713) | 1,678* (3,700)* | 1,238 (2,731) | 1,058 (2,332) | 2,413* (5,322)* | 1,888 (4,163) | 1,577 (3,478) | - | - | - |
| 0,0 m (0'-0") | | 1,365* (3,010)* | 908 (2,002) | 781 (1,723) | - | - | - | 1,800* (3,968)* | 1,210 (2,667) | 1,031 (2,272) | 2,645* (5,832)* | 1,835 (4,046) | 1,528 (3,369) | - | - | - |
| -1,0 m (-3'-3") | | 1,386* (3,057)* | 1,021 (2,251) | 875 (1,930) | - | - | - | 1,716* (3,785)* | 1,203 (2,653) | 1,024 (2,259) | 2,504* (5,522)* | 1,828 (4,030) | 1,521 (3,354) | 4,032* (8,891)* | 3,729 (8,223) | 2,905 (6,406) |
| -2,0 m (-6'-7") | | 1,348* (2,973)* | 1,345 (2,965) | 1,143 (2,520) | - | - | - | - | - | - | 1,957* (4,314)* | 1,855 (4,091) | 1,547 (3,411) | 3,009* (6,635)* | 3,009* (6,635)* | 2,956 (6,518) |

Tab.7: Lifting force table ET58 STD, short dipper stick, steel track, with additional rear weight

| | | | | | 5,0 m (16'-5") | | | 4,0 m (13'-1") | | | 3,0 m (9'-10") | | | 2,0 m (6'-7") | | |
|--------------------|---|--------------------|--------------------|------------------|--------------------|----------------|----------------|--------------------|--------------------|------------------|--------------------|--------------------|--------------------|--------------------|--------------------|------------------|
| A | B | | | | | | | | | | | | | | | |
| | | Blade down | Blade up | | Blade down | Blade up | | Blade down | Blade up | | Blade down | Blade up | | Blade down | Blade up | |
| 4,0 m (13'-1") | | 1,220* (2,690)* | 1,180* (2,602)* | 1,016 (2,240) | - | - | - | 1,168* (2,576)* | 1,168* (2,576)* | 1,134 (2,501) | - | - | - | - | - | - |
| 3,0 m (9'-10") | | 1,204* (2,654)* | 946 (2,087) | 816 (1,800) | - | - | - | 1,177* (2,595)* | 1,177* (2,595)* | 1,127 (2,486) | - | - | - | - | - | - |
| 2,0 m (6'-7") | | 1,216* (2,680)* | 847 (1,868) | 730 (1,610) | 1,228* (2,709)* | 909 (2,004) | 783 (1,727) | 1,361* (3,001)* | 1,277 (2,815) | 1,093 (2,411) | 1,661* (3,662)* | 1,661* (3,662)* | 1,661* (3,662)* | - | - | - |
| 1,0 m (3'-3") | | 1,241* (2,737)* | 815 (1,796) | 701 (1,546) | 1,306* (2,880)* | 891 (1,965) | 766 (1,689) | 1,600* (3,528)* | 1,232 (2,716) | 1,050 (2,316) | 2,270* (5,006)* | 1,891 (4,169) | 1,578 (3,480) | - | - | - |
| 0,0 m (0'-0") | | 1,273* (2,807)* | 836 (1,843) | 718 (1,583) | 1,341* (2,958)* | 877 (1,934) | 753 (1,659) | 1,762* (3,855)* | 1,197 (2,639) | 1,017 (2,243) | 2,598* (5,729)* | 1,822 (4,019) | 1,515 (3,340) | - | - | - |
| -1,0 m (-3'-3") | | 1,302* (2,870)* | 927 (2,043)* | 794 (1,750) | - | - | - | 1,743* (3,843)* | 1,184 (2,610) | 1,005 (2,216) | 2,551* (5,625)* | 1,805 (3,979) | 1,498 (3,304) | 4,306* (9,494)* | 3,681 (8,117) | 2,861 (6,308) |
| -2,0 m (-6'-7") | | 1,296* (2,857)* | 1,170 (2,580) | 996 (2,197) | - | - | - | 1,368* (3,015)* | 1,202 (2,650) | 1,022 (2,253) | 2,126* (4,689)* | 1,824 (4,021) | 1,516 (3,343) | 3,393* (7,481)* | 3,393* (7,481)* | 2,906 (6,408) |

Tab.8: Lifting force table ET58 STD, long dipper stick, steel track, with additional rear weight